

**Parking permits: see page 3 (Do not purchase one online)**  
**The \$1 fee is optional. You are not required to pay.**

- Go to: [www.piercecollege.edu](http://www.piercecollege.edu) Jan. 12, 2012 9:00 a.m. – midnight  
 Jan. 13 - Feb. 2 7:00 a.m. – midnight 7 days a week

- On the top right corner click on **Class Registration**.

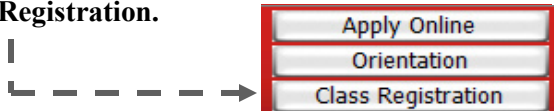

**Important**  
 Only the following browsers are Supported:

- Internet Explorer
- Mozilla Firefox

- Student Identification Number (SID):** Enter your Student ID Number. As a continuing student, your Student ID number can be found on the continuing student notice that was mailed in early January. If you did not receive the notice please call the office, (818) 710-2561.

8	8							
---	---	--	--	--	--	--	--	--

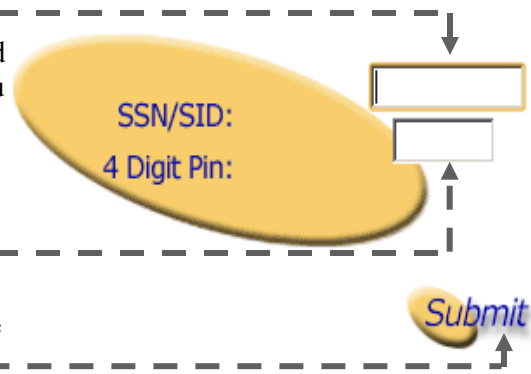

- PIN:** (Personal Identification Number) – Your PIN is the **month** and **day** of your birth. If your birthday is March 5, enter 0305. If you changed your PIN while using the Pierce website, your new PIN must be used. Once finished, click on **Submit**.

--	--	--	--

- Click **Registration** (4<sup>th</sup> option on the menu to the right).



- College:** Los Angeles Pierce College  
**Semester:** Spring 2012  
**Action:** Add  
**Section:** Enter 4-digit number usually under the class title in the Encore catalog.  
*All ENCORE section numbers begin with 88.*  
 After the information is filled out, click **Submit**.

Registration	
<b>College:</b>	Los Angeles Pierce College
<b>Semester and Year:</b>	Spring 2012
<b>Action:</b>	Add
<b>Section Number:</b>	88
<b>Submit</b>	

**NOTE:** if prompted for a major code and the hours you work, select undecided for the major code and input “00” for the hours you work.

○○○ **To add another class go back to step 5** ○○○

- IMPORTANT: Review & print your class schedule including your Wait List number** by following the directions to step 4 and clicking **View Schedule** (instead of Registration). Fill in College-Los Angeles Pierce College, semester **Spring**, year **2012**. Click **submit**. **Print** your schedule to confirm your registration went through.

Class Schedule	
<b>College:</b>	Los Angeles Pierce College
<b>Semester:</b>	Spring
<b>Year:</b>	(Ex: 2012) <input type="text"/>
<b>Submit</b>	

**Help with Registration**

- For technical problems with web registration, call (818) 719-6404
- Call the ENCORE office at (818) 710-2561 if you have any of the following problems:
  - No registration appointment
  - If there is a health fee hold